

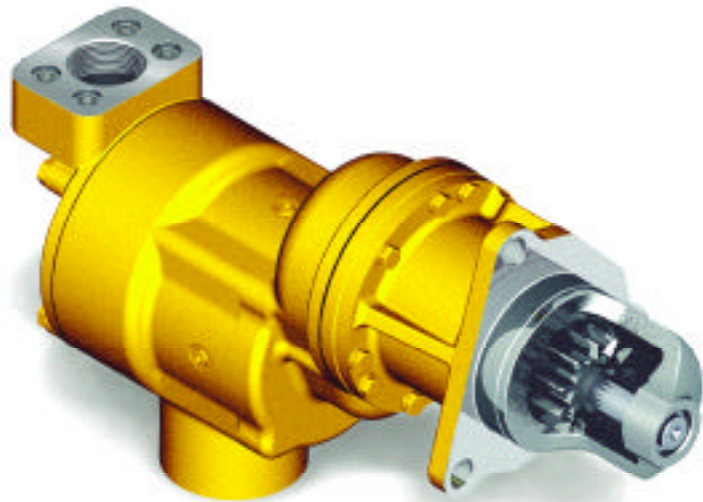

Air Starters

150T Series



For engine displacement of: Diesel—500 to 2000 CID (8 to 32 liters)
Carburated—1000 to 4000 CID (16 to 64 liters)

Features/Benefits

- Same inlet and outlet locations as the 150BM starter for easy change-out
- Uses the proven front end of the 150BM starter
- Provides maintenance-free operation
- Sealed for use in gas and air applications
- Efficient 30 hp turbine motor uses no external lubrication

Versatile

- Inertia and pre-engaged models available
- Left- and right-hand rotation available
- 4 inlet, 4 exhaust, and 16 drive housing orientations
- 30-150 psi operation



Industry applications ideal for the 150T Series starters: marine, trucking, transit, oil and gas.



Series 150T DIMENSIONS

Weight lbs (kg)	
150T	35 (15.9)

Note: All dimensions shown are for reference only. Specifications subject to change without notice.

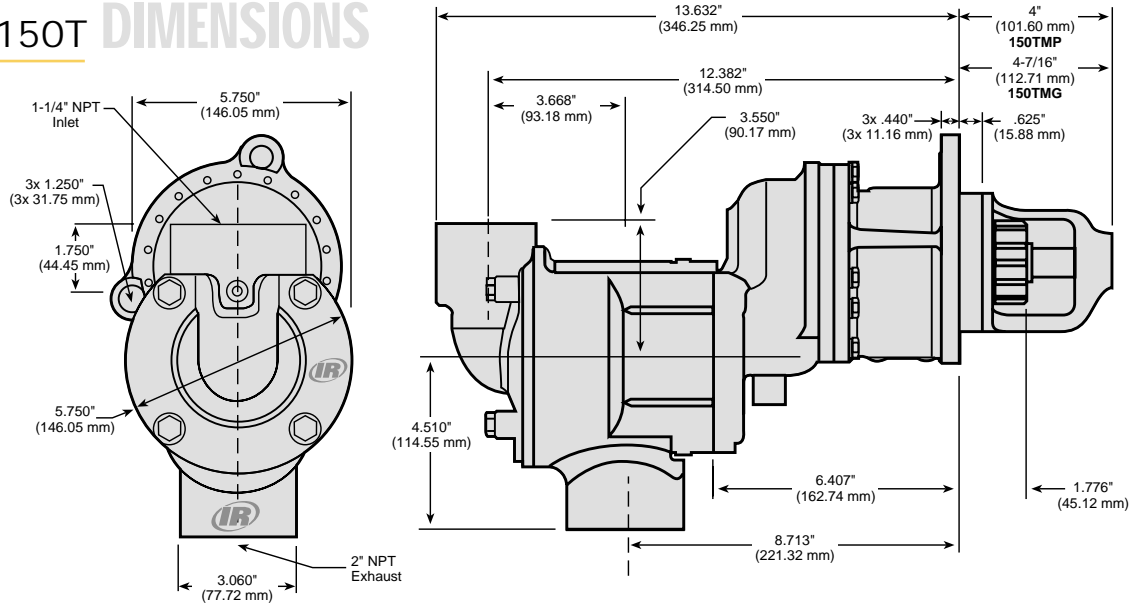

150TMPE/150TMGE Performance Information

Pressure PSI (bar)	Breakaway Torque ft-lb (Nm)	Speed @ Max HP RPM	Max HP	Flow @ Max HP SCFM (L/s)
60 (4.1)	60 (81)	1750	9	310 (146)
90 (6.2)	80 (108)	1950	15	430 (203)
120 (8.3)	125 (169)	2000	24	570 (269)
150 (10.3)	150 (203)	2300	32	710 (335)

150TLP Performance Information

Pressure PSI (bar)	Breakaway Torque ft-lb (Nm)	Speed @ Max HP RPM	Max HP	Flow @ Max HP SCFM (L/s)
30 (2.1)	55 (75)	1600	8	300 (142)
60 (4.1)	105 (142)	1800	16	510 (241)
90 (6.2)	135 (183)	1900	25	720 (340)

150T Series Number of Starts per Tank

(Data taken from crank tests on Detroit Diesel Series 50 with an Allison Transmission)

Max Tank Pressure (psi)	300	19	28	37	47	56	65	75	84	20	Max Tank Pressure (bar)	
	270	16	24	33	41	49	57	65	73	18		
	240	14	21	28	35	42	49	56	63	16		
	210	12	17	23	29	35	41	47	52	14		
	180	9	14	19	23	28	33	37	42	12		
	150	7	10	14	17	21	24	28	31	10		
	120	5	7	9	12	14	16	19	21	8		
	90	2	3	5	6	7	8	9	10	6		
		40	60	80	100	120	140	160	180			
		151	227	302	378	454	529	605	680			
	Tank Size									Gallons Liters		

150T Series

Bold Model Numbers indicate that a remanufactured model is available with the same part number (add an "R" to the number).

Most Obsolete Units ▶

150T Series Crossover Model Numbers

150T Available Units	150BM Crossovers	150LF Crossovers	150BM Obsolete	150BM Obsolete	10BM Obsolete	9BM Obsolete
150TME21RH-31	150BME21RH-31			101BMPC78RH-31	10BMB21RH-31	
150TMGE12RH-13	150BMGE12RH-13			150BME12RH-13	10BMB12RH-13	9BMA43RH-13
150TMGE21LH-11	150BMGE21LH-11	150LFGE21LH11-000	150BME21LH-11		10BMB21LH-11	9BMB31LH-11
150TMGE21LH-11	150BMGE21LH-11				10BMB22LH-8	9BMA32LH-8
150TMGE21LH-32	150BMGE21LH-32					
150TMGE21RH-6	150BMGE21RH-6	150LFE21RH6-020	150BME21RH-6		10BMB21RH-6	9BMA331RH-6
150TMGE21RH6-22R	150BMGE21RH6-22R	150LFGE21RH6-000	150BME21RH-17			
150TMGE22RH-5	150BMGE22RH-5	150LFGE22RH5-020	150BME22RH-5			
150TMGE22RH5-10D	150BMGE22RH5-10D		150BMGE22RH-5		10BMB12RH-13	9BMA43RH-13
150TMPD88L54-020	150BMPD88L54-020					
150TMPD88R54-020	150BMPD88R54-020		150BMPD88R-46	150BMPD89RH-46		
150TMPE81R15-00N	150BMPE81R15-00N	150LFPE81R15-020				
150TMPE88L54-11A	150BMPE88L54-11A			150BMPD89LH-50	101BMPC78LH-11	
150TMPE88L54-12E	150BMPE88L54-12E		150BMPE88L-11	15BMPE78LH-11		
150TMPE88L54-13E	150BMPE88L54-13E		150BMPE88L-11	150BMPE83LH-11	10BMB21LH-11	9BMB31LH-11
150TMPE88L54-200	150BMPE88L54-200	150LFPE88L54-000				
150TMPE88L54-20N	150BMPE88L54-20N					
150TMPE88L54-22N	150BMPE88L54-22N					
150TMPE88L54-33A	150BMPE88L54-33A					
150TMPE88L54-33C	150BMPE88L54-33C					
150TMPE88R51-200	150BMPE88R51-200	150LFPE88R51-020				
150TMPE88R53-000	150BMPE88R53-000		150BMPE88R-53	150BMPE78RH-53	101BMPC78RH-38	
150TMPE88R53-020	150BMPE88R53-020	150LFPE88R53-020	150BMPE88R-53	150BMPE78RH-5	10BMB22RH-5	9BMA32RH-5
150TMPE88R53-12F	150BMPE88R53-12F					
150TMPE88R53-200	150BMPE88R53-200					
150TMPE88R53-300	150BMPE88R53-300					
150TMPE88R54-000	150BMPE88R54-000	150LFPE88R54-000	150BMPE88R-44	150BMPE78RH-44	101BMPB78RH-44	
150TMPE88R54-00N	150BMPE88R54-00N	150LFPE88R54-00N	150BMPE88R-54	150BMPE78RH-54		
150TMPE88R54-02E	150BMPE88R54-02E	150LFPE88R54-02E		150BMPE78RH-6	101BMPC78RH-6	
150TMPE88R54-12C	150BMPE88R54-12C					
150TMPE88R54-12D	150BMPE88R54-12D	150LFPE88R54-12D				
150TMPE88R54-12E	150BMPE88R54-12E	150LFPE88R54-12E				
150TMPE88R54-200	150BMPE88R54-200	150LFPE88R54-200				
150TMPE88R54-20E	150BMPE88R54-20E					
150TMPE88R54-220	150BMPE88R54-220					
150TMPE88R54-22E	150BMPE88R54-22E					
150TMPE88R54-300	150BMPE88R54-300	150LFPE88R54-300				
150TMPE88R54-32P	150BMPE88R54-32P					
150TMPE88R54-POS	150BMPE88R54-POS					

Simple Crossover:

Current 150BM models are superseded to the 150T models by replacing the "B" with a "T."

Example: 150**B**MPE88R54 = 150**T**MPE88R54

For low pressure applications (less than 90 psi or 6.2 bar) replace the "M" with an "L."

Example: 150**M**PE88R54 = 150**L**LPE88R54

150T SERIES MODEL CODING



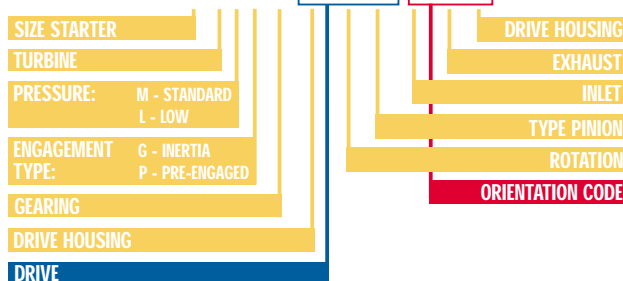



150 T M G E 21 RH 6 0 2 F



Air Starters

150T Series Accessories

See catalog pages I-1 to I-20 for detailed Accessory information.

IR Part #	Description	Picture
1 ST500-674	2" Muffler	
2 150BMP-1051B	1/4" 12 V Solenoid Valve	
3 150BMP-2451B	1/4" 24 V Solenoid Valve	
4 SMB-618	Push Button Valve	
5 SMB-G618	Gas Rated Push Button Valve	
6 SRV125T	1-1/4" Relay Valve For Transit	
7 SRV125	1-1/4" Relay Valve For Stationary Air	
8 SRV150SS	1-1/2" Gas Rated Relay Valve	

IR Part #	Description	Picture
9 150BMP-1058	Gladhand	
10 150BMP-1064	1/8", 150 psi Pressure Gauge	
11 ST900-267-24	1-1/2" Strainer (300 Mesh)	
12 ST900-266-24	1-1/2" Strainer Element (300 Mesh)	
13 ST500-A735	2" Road Splash Deflector	
14 150BMP-1056	1/2" Check Valve	
15 150BMP-1067	1/2" Drain Valve	
16 ST500-K166	SAE J518 Split Flange	

Red item numbers correspond to numbers in diagrams on page A-4.

150T Series Genuine Ingersoll-Rand Replacement Kits:

Tune Up Kit Part Number	Description
150TMP-TK1	150T Pre-engaged Starter Tune Up Kit
150TMG-TK1	150T Inertia Starter Tune Up Kit
150TMPD-TK1	150T D-Ratio Starter Tune Up Kit

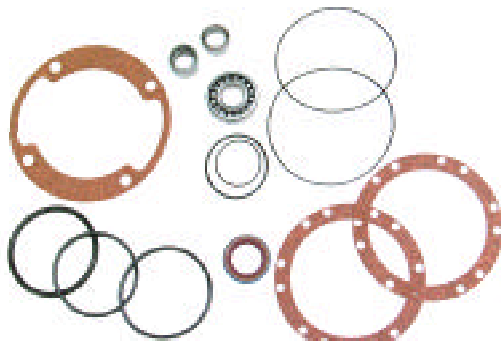

150TMP-TK1 Parts



150TMG-TK1 Parts

150T Series

150T (Gas) Stationary Installation

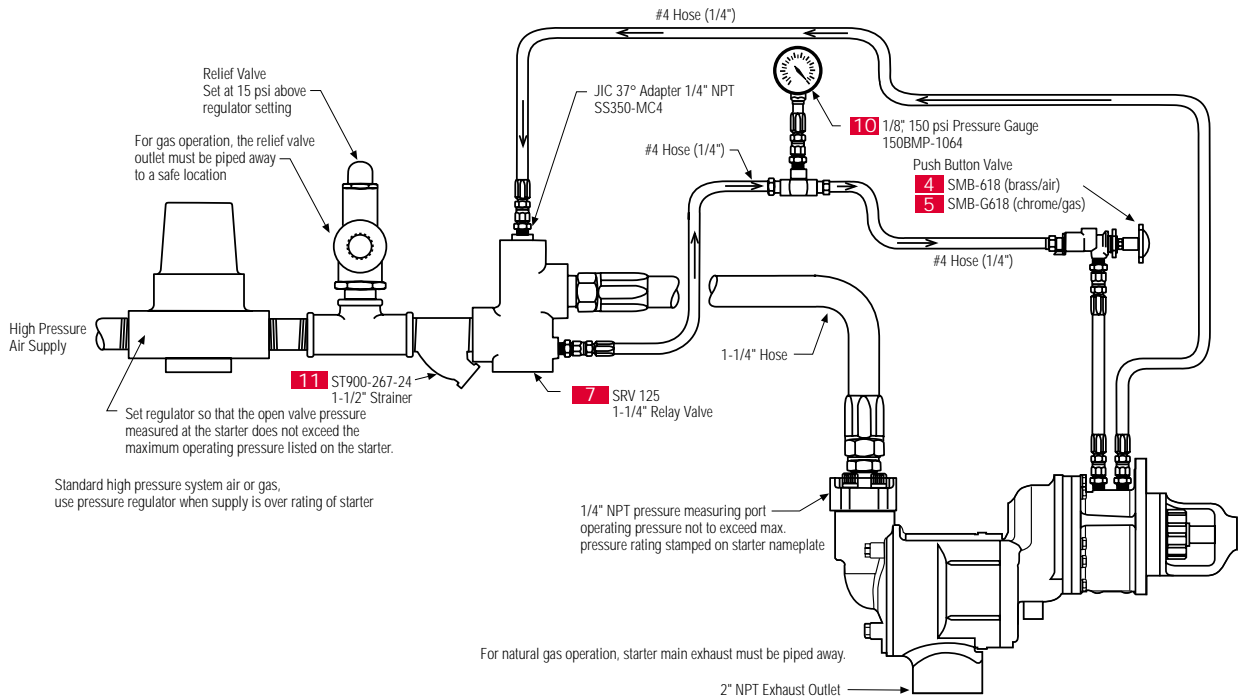

150T Typical Vehicular Installation

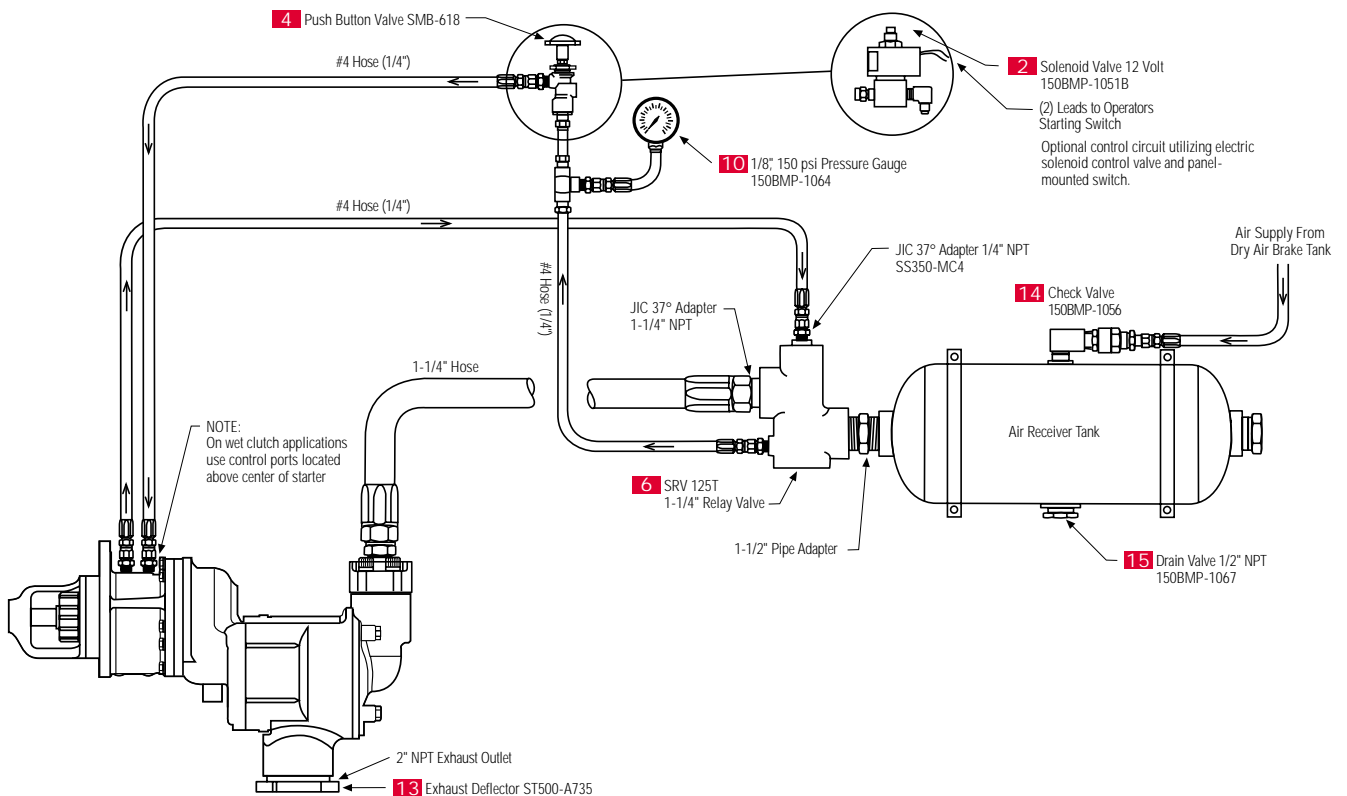



Series 150T Air Starters

150T Series Engine Selection Guide

This chart is a condensed list of engines that can be cranked with an IR starter. For a complete list, please contact IR.

Manufacturer	Engine	CID	Liter	CYL	Type	Turbine Starter
CATERPILLAR	3126	439	7.2	6	Diesel	150TMPE81R15
	3176	629	10.3	8	Diesel	150TMPE88R54
	3406	893	14.6	6	Diesel	150TMPE88R54
	3408	1099	18	8	Diesel	150TMPE88R54
	D-334	638	10.5	6	Diesel	150TMPE88R53
	D-336	700	11.5	8	Diesel	150TMPE88R53
	D-343	893	14.6	6	Diesel	150TMPE88R54
	D-346	1191	19.5	8	Diesel	150TMPE88R54
	G-342	1246	20.4	6	Nat. Gas	150TMPE88R54
CES-AJAX	DP125	2205	36.1	1	Nat. Gas	150TMGE21LH-11
	DP165	2826	46.3	1	Nat. Gas	150TMGE21LH-11
	DPC180	2826	46.3	1	Nat. Gas	150TMGE21LH-11
	DPC60	850	14	1	Nat. Gas	150TMGE21LH-11
CLIMAX	K67	1616	26.5	6	Gas	150TMPE88R53
	K75	1855	30.4	6	Gas	150TMPE88R53
	R165	1238	20.3	6	Gas	150TMPE88R53
CONTINENTAL	R602	602	9.9	6	Gas	150TMPE88R53
	R6513	513	8.4	6	Gas	150TMPE88R53
	U6501	501	8.2	6	Gas	150TMPE88R53
CUMMINS	ISC	506	8.3	6	Diesel	150TMPE88R53
	ISL	549	9	6	Diesel	150TMPE88R53
	N-14 SERIES	855	14	6	Diesel	150TMPE88R54
	N-855 SERIES	855	14	6	Diesel	150TMPE88R54
	ISM	659	10.8	6	Diesel	150TMPE88R54
	ISX	915	15	6	Diesel	150TMPE88R54
DETROIT DIESEL	6V-71	426	7	6	Diesel	150TMGE21RH6
	6V-92	552	9	6	Diesel	150TMGE21RH6
	Series 50	519	8.5	4	Diesel	150TMPE88R54
	Series 60	778	12.7	6	Diesel	150TMPE88R54
EMD GM	12-645	7740	126.8	12	Diesel	2-150TMPD88R54
	12-710	8520	139.6	12	Diesel	2-150TMPD88R54
	16-645	10320	169.1	16	Diesel	4-150TMPD88R54
	16-710	11360	186.2	16	Diesel	4-150TMPD88R54
	20-645	12900	211.4	20	Diesel	4-150TMPD88R54
	20-710	14200	232.7	20	Diesel	4-150TMPD88R54
	8-645	5160	84.6	8	Diesel	2-150TMPD88R54
	8-710	5680	93.1	8	Diesel	2-150TMPD88R54
WAUKESHA	145GZ	817	13.4	6	Nat. Gas	150TMGE22RH5
	6GAK	784	12.8	6	Nat. Gas	150TMGE22RH5
	6WAK	1197	19.6	6	Nat. Gas	150TMGE21RH6
	F1197G	1197	19.6	6	Nat. Gas	150TMGE21RH6
	F119G	1197	19.6	6	Nat. Gas	150TMGE21RH-6
	H1077G	1077	17.6	8	Nat. Gas	150TMGE21RH6
	H24L	1462	24	8	Nat. Gas	150TMGE21RH6
	H867D	866	14.2	8	Diesel	150TMPE88R53
WHITE ENGINES	DFXD	855	14	6	Diesel	150TMPE88R54
	DFXE	895	14.7	6	Diesel	150TMPE88R54